

CARAT

OPERATION MANUAL

ASPHALT AND CONCRETE CUTTER

RVZ-500



Congratulations! You have purchased an asphalt and concrete cutter. You receive a high-quality and powerful machine, intended for professional use under the heavy duty conditions.

Read this operation manual carefully before starting the machine and always keep this manual - in this way you will secure safe operation, high working output and long durability of the machine.

The manufacturer bears no responsibility for damages arising from not keeping the operation manual.

CONTENT:

1. SAFETY INSTRUCTIONS	3
1.1. GENERAL INSTRUCTIONS	3
1.1.1 Requirements for qualification of the operator.....	3
1.1.2 Contractor's obligations.....	3
1.1.3 Operator's obligations.....	3
1.1.4 Operation of the machine.....	4
1.1.5 Maintenance and Service.....	4
1.1.6 Transport and Storage.....	4
1.1.7 Testing.....	4
1.2. PROHIBITED ACTIVITIES	5
1.3. HYGIENIC PRINCIPLES	5
1.4. ENVIRONMENTAL PRINCIPLES	5
1.5. LIQUIDATION OF THE MACHINE	5
1.6. SAFETY INSTRUCTIONS	6
1.7. HYGIENIC DATA	6
2. TECHNICAL DESCRIPTION	7
2.1. BASIC TECHNICAL DATA	7
2.2. LUBRICANTS	8
2.3. IDENTIFICATION	8
2.4. ENGINE IDENTIFICATION	8
3. PRIOR TO STARTING	9
3.1. CHECK-OIL LEVEL	9
3.2. VISUAL INSPECTION OF THE MACHINE	9
3.3. ADDING FUEL	9
3.4. CHECK-AIR FILTER	9
4. OPERATION	10
4.1. STARTING	10
4.1.1 Gasoline engines HONDA.....	
4.2. OPERATION	10
4.2.1 Selection of the cutting disc.....	10
4.2.2 Fastening of the cutting disc	11
4.2.3 Cutting.....	11
4.2.4 Cutting depth scale.....	11
4.3. ENGINE TURNING-OFF	11
4.4. HANDLING, TRANSPORT, STORING	12
4.4.1 Manual handling.....	12
4.4.2 Handling by crane.....	12
4.4.3 Handling by forklift.....	12
4.4.4 Transport.....	12
4.4.5 Storing.....	12
4.5. SPECIAL CONDITIONS OF OPERATION	13
4.5.1 Work at low temperatures	13
4.5.2 Work at high altitudes	13
4.5.3 Work in dusty environment.....	13
5. MAINTENANCE	14
5.1. MAINTENANCE OF THE ENGINE.....	14
5.2. TENSIONING OF THE DRIVE BELTS	14
5.3. INSPECTION OF BOLTED CONNECTIONS	14
5.4. ADJUSTMENT OF ENGINE SPEED	14
6. MAINTENANCE SCHEDULE	15

1. SAFETY INSTRUCTIONS

1.1. General instructions for operation of light construction equipment

1.1.1. Requirements for qualification of the operator

1. The machine must be operated by trained reliable operators of age above 18. The operator must read and understand the safety instructions, the regulations valid for the respective jobsite and valid technological procedure. This should be proved by getting the operator's signature.
2. The operator is obliged to use suitable working dress, safety gloves and firm boots with hard tip. Do not wear loose or torn clothes, chains or jewelry that could be caught by moving parts of the machine. The operator is obliged to use safety goggles and ear protection.
3. The machine may be used for intended purpose only, in accordance with this operation manual.

1.1.2. Contractor's obligations

The contractor is understood to be a physical or legal person that carries out construction works and for such purpose uses construction equipment. The contractor is responsible for operational safety.

The contractor is obliged to:

- designate the operator and arrange his training
- ensure safe working conditions
- inspect attendance of the safety regulations

- inspect that the operator works with the machine in accordance with the Operation Manual
- ensure regular inspections, maintenance and repairs of the machine
- store the Operation Manual so that it is readily available
- arrange suitable, safe and adequate storing of the machine when not in use

The contractor is also responsible for proper attendance of lawful regulations of work safety and regulations valid for each respective jobsite.

1.1.3. Operator's obligations

The operator is to be designated by the contractor, while keeping conditions of the article 1.1.1.

The operator is namely obliged to:

- prior to starting, he should read and understand the Operation Manual including the safety instructions
- attend all instructions of the Operation Manual
- learn about the jobsite and the locally valid safety regulations; these must be kept during the work
- pay full attention to operation of the machine

- arrange that regular inspections, maintenance and repairs of the machine are carried out as according to the Operation Manual
- require from the contractor proper conditions for keeping safety instructions, regular inspections, maintenance and repairs
- avoid damage, misuse or unauthorized use to the machine, namely by proper storing the machine to a secured place

1.1.4. Operation of the machine

Before starting:

1. Check the machine thoroughly, repair all failures before starting the engine. If the failures cannot be repaired at the jobsite, do not operate the machine.
2. Check the fuel system for leaking. Dripping fuel poses fire hazard.

Starting and operation:

3. When starting the engine, take stable position and held the grip firmly.
4. The controls must be in good order.
5. The operator must not leave from his position when the engine is running.
6. Stop the engine before interrupting the work. When parking the machine, secure it from falling.
7. Stop the engine before refueling. Avoid contact between fuel and hot parts of the engine. Let the engine to cool down first.
8. Keep the fuel tank tightly closed. Close the fuel tap when not in operation. Drain the fuel before transporting the machine for longer distances.

DANGER! Leaking fuel tank and distribution may cause explosion. Replace these parts immediately if damaged.

Jobsite:

9. No bystanders are allowed within the operational range of the machine. Especially children should be kept in safe distance.
10. Do not operate the machine in areas with explosion danger.
11. If operated in closed spaces (halls, tunnels), there should be ensured sufficient ventilation.
12. Held and guide the machine with high care in order to avoid hands injury caused with contact with an obstacle.
14. Do not smoke, do not use naked flame. Do not work close to flammables or in explosion danger areas.
15. Avoid touching hot parts. The exhaust silencer and other parts of the engine are very hot during operation and touching them can cause serious burns.

1.1.5. Maintenance and Service

1. Do not remove any covers or other safety devices. In case this must be done because of service, install all the parts back before starting.
2. Use genuine spare parts only. Do not carry out any modifications without prior written approval of the manufacturer.
3. Stop the engine before servicing the machine.

1.1.6. Transport and Storage

1. When loading and transporting the machine fasten the machine properly on the carrier.
2. The machine is to be transported in upright position (with engine upwards). This position is also suitable for storing.
3. Prior to long-term storage: Conserve the machine, cover it and store it at safe, dry and ventilated place.

1.1.7. Testing

It is recommended to test the machine by authorized service at least once a year or more often if used under heavy conditions.

If necessary, carry out repairs of all possible failures.

1.2. Prohibited activities

Never:

- use the machine for other than intended purposes
- use the machine in other way than as described in the Operation Manual
- operate the machine drunk or intoxicated
- operated the machine if its operation could cause harm to other people
- start and operate the machine if there are other people within the dangerous area
- operate the machine if some safety device (i.e. cover) is damaged or missing
- operate the machine in areas with external risks (risk of soil flow, dangerous fumes, risk of explosion, risk of electrical shock, etc.)
- operate the machine in areas where its operation may cause damage to buildings, structures or utility lines
- operate the machine within the protective range of power lines or transformer stations
- operate the machine under poor visibility or at night, unless the jobsite is sufficiently illuminated
- leave unprotected machine
- disable or modify safety devices, protective and safety systems
- operate the machine with leaking oil, fuel or other liquids
- start the engine in other way than described in the Operation Manual
- clean a running machine
- smoke or use naked flame when refueling

1.3. Hygienic principles

Oil derivatives (fuel, lubricants) as well as paints and thinners are harmful agents. Anyone who gets into contact with such agents is obliged to protect himself and follow general principles health protection as well as to follow instructions valid for each specific agent.

Pay special care to:

- skin care
- wash hands properly after finishing the work and apply suitable cream

Store the fuels, lubricants, paints, thinners, cleansing and conservation agents, as well as other dangerous agents in original containers, properly sealed. Never allow storing in unmarked bottles or containers or even in beverage bottles. Store such agents in safe place, out of reach of children.

In case that the agent gets into touch with skin or eyes, or when it is eaten or inhaled, apply the first aid and get immediately medical aid.

1.4. Environmental principles

Fuel, lubricants and other operational fluids are harmful to environment. This category also includes part of the machine that get into contact with operational fluids, such as filter and hydraulic hoses.

After use these belong to dangerous waste.

Pay high attention to avoid leakage of the fluids and their escape into soil or water (including the sewage).

Store the fluids in such manner, that the fluids gets caught in case of accidental leakage.

If these agents still escape, arrange their safe collection and liquidation.

1.5. Liquidation of the machine

After the machine exceeds its lifetime period, the contractor is obliged to arrange its proper liquidation in accordance with the respective

lawful regulations and with regards to environmental protection.

It is highly recommended to commit this task to a specialized company.

1.6. Safety instructions

Besides of general safety instruction, the following special instruction must be followed:

1. Prior to starting the work, find out where are underground spaces, utility lines, etc.
2. Never remove the blade cover when the engine is running.
3. After stopping the engine, wait till the blade gets fully halted.
4. After fitting the cutting blade, pace on the cover and secure it.
5. Be sure to remove the wrenches from the blade shaft!
6. Do no allow other people close to running machine.
7. **DANGER!**
The cutting blade is always turning as soon as the engine is started. The revolving blade presents a risk of injury!

1.7. Hygienic data

	RVZ-500
Noise level	104,5 dB(A)
Acoustic power	115,6 dB(A)
Acceleration transferred to hands	14,5 m/s ²

	RVZ-500
1. Because of the noise level, the operator is obliged to use ear protection effective for the noise level:	105 dB(A)
2. Work with the machine must be interrupted regularly, the breaks should last at least:	10 min.

3. Technological procedures should be adapted to suit the safety breaks.
4. The operator shouldn't be exposed to excessive noise and/or vibrations during the safety breaks.
5. Should the limits of maximal exposition be exceeded, the working position should be pronounced as "risky" and the respective authorities should be informed.
6. Operation in or close to residential areas is restricted from 6.00 a.m. to 6.00 p.m.

2. TECHNICAL DESCRIPTION

The RVZ-500 is intended for cutting of asphalt and concrete floors or road layers when repairing roads, industrial areas, etc.

The machine is based on a rigid frame with fixed spindle; the cutting disc is lowered to the cut together with the whole frame. Lowering and rising of the cutting disc is controlled by means of a arrested handle that enables fine regulation of cutting depth.

The machine is intended for wet cutting and therefore it is equipped with a sprinkling system.

Water for sprinkling can be brought either from machines-mounted water tank or from external source.

The machines can be used also for dry cutting, assuming a suitable cutting disc is used. This method however causes high generation of dust and thus breathing protection would be required. The machine is driven by a single-cylinder, four-stroke gasoline engine HONDA.

Travel is manual; the operator pushes the machines by height-adjustable handle.

2.1. Basic Technical Data:

		RVZ-500
Cutting depth	(mm)	170
Cutting disc fastening		at right
Max. disc dia	(mm)	500
Travel		manual
Cutting depth adjustment		manual
Arbor hole dia	(mm)	25,4 + PH
Spindle speed	(RPM)	2800
Water tank capacity	(ltr)	20
Weight	(kg)	106
Dimensions L x W x H	(mm)	1050x530x1040
Engine		HONDA
Type		GX 390 Cyclon
Power	(kW)	9,6
Speed	(RPM)	3600
Oil sensor		yes
Fuel consumption	(ltr/hr)	1,5



2.2. Lubricants

Use brand lubricants according to the specification below only:

- engine oil	15W-40	API SG/CF 4, API SG/CE
	content - depending on engine	HONDA approx. 1,1 ltr

2.3. Identification

For communication with the manufacturer (i.e. for warranty claims, service requests, spare parts ordering) always report exact model and serial number of your machine.

These data are stamped on the machine decal.

2.4. Engine Identification

In case of problems related to the engine report also engine type and serial number. This number is stamped on the engine block of the HONDA engine.

3. Prior to Starting

3.1. Check - Oil Level

It is highly recommended to check regularly the engine oil level even on machines equipped with the oil sensor.

Clean the filling hole before checking or adding oil. Wipe dry the dipstick and immerse it in the oil without screwing it in.

If necessary, add specified sort of oil up to the upper mark.

NOTE :

Operation with insufficient oil level may cause serious damage to the engine.

Check the engine oil level daily!

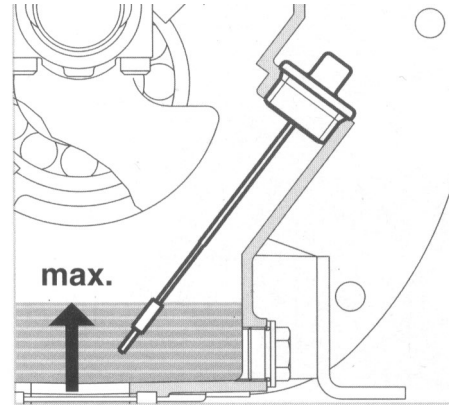

3.2. Visual Inspection of the Machine

Check regularly the machine for:

- missing parts
- released bolts and screws
- oil or fuel leakage

- free motion of the cutting disc spindle
- Pay special attention to safety devices (covers) and controls.

3.3. Adding Fuel

1. Gasoline engines:

Use unleaded or leaded gasoline for motor vehicles, with octane number 91 or more.
Top up fuel as necessary.

Never use dirty fuel or mixture with oil.
Avoid water and dust from entering the fuel tank.

3.4. Check - Air Filter

Check the air filter for cleanness on a daily basis. Clean or replace the filter if dirty.

Never run the machine with air filter missing or damaged. Dust and dirt which get into the engine would cause rapid wear.

Fig. Air filter - HONDA

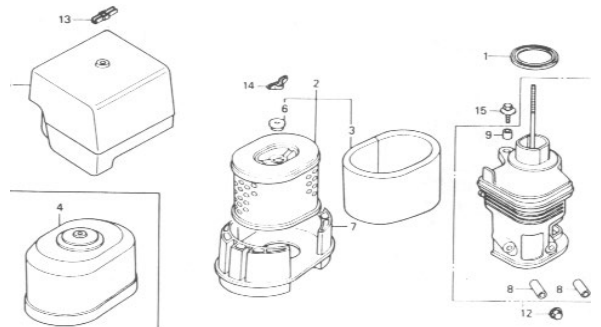

4. Operation

4.1. Starting

4.1.1. Gasoline Engine HONDA

1. Turn the fuel tap into the ON position.

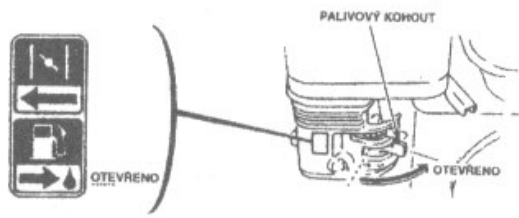

2. Turn on the electric switch of ignition .

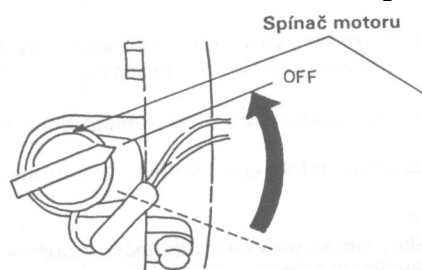

3. Engage the choke („CHOKE“). Do not use it at warm engine or at high ambient temperature.

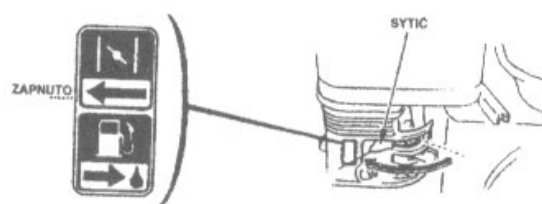

4. Adjust the throttle control lever to idle.
5. Pull out the starter grip slowly till some resistance is felt, then pull vehemently. Do not release the grip, but return it slowly into the original position.
6. Let the engine warm up, then disengage the choke.
7. Let the engine run at idle for a while before applying full load.
8. For cutting, shift the throttle control lever to fully open position.

DANGER!

The spindle and the cutting disc start to rotate immediately. Be sure that the revolving disc can not cause any danger for the bystanders. Have the disc cover installed before starting.

4.2. Operation

4.2.1. Selection of the Cutting Disc

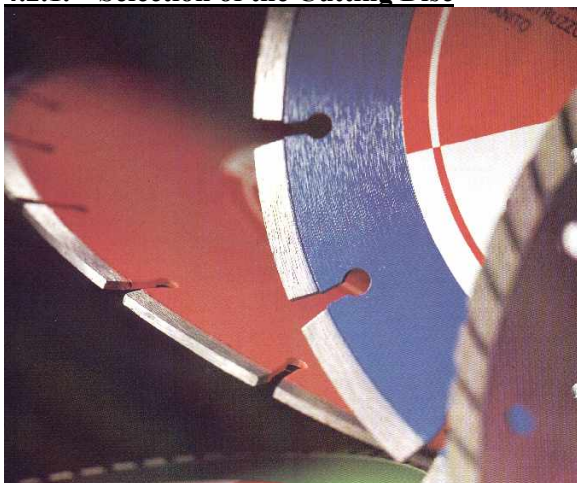

For safe and efficient operation, right selection of the cutting disc is highly important. Choose a high-quality diamond cutting disc and appropriate type depending on the material to be cut (asphalt, concrete).

Cutting discs of most suppliers are divided in quality categories (standard/profi etc.), sometimes also according to length and height of the diamond segments, spacing, etc.

Cutting disc diameter is to be selected according to the type of the machine; if possible, choose always the maximal allowed diameter. The spindle speed is adjusted for this size to keep optimal circumferential cutting speed of the disc.

4.2.2. Fastening of the Cutting Disc

1. Turn off the engine and open the disc cover.
2. Use the enclosed wrenches to hold the spindle and unscrew the fastening nut.
NOTE: Left thread!
3. Fit the cutting disc on the spindle and secure it. Pay attention to the right sense of direction – see arrow on disc.
4. Close the disc cover and secure it.

Fig. Location of wrenches**4.2.3. Cutting**

1. Have the disc raised above floor.
2. Disengage the emergency button (counter clockwise)
3. On/off switch on motor in on-position
4. Start the motor with the recoil and set to full throttle.
5. Open the water tap to engage sprinkling.
6. Move the machine to the beginning of the cut.
7. Lower slowly the disc into the cut, till required cutting depth is reached.
8. Sensitively push the machine forward and follow the marked path (use the guide).
9. The machine can only cut in straight direction. In case the direction must be

- changed, raise the disc from the cut, take new direction and lower the disc again.
7. At the end of the cut, raise the disc, set the throttle to idle.

NOTE! Check the water level in the tank and timely add water if necessary.

For optimal service life of the cutting disc, the operator should work carefully and sensitively. Do not force the machine!
Nevertheless, lifetime of the disc may vary depending on the material to be cut and other factors.

4.2.4. Cutting Depth Scale

Cutter RVZ-500 has a cutting depth scale. Use the scale as follows:

1. Lower the disc just to touch the ground. In this position, adjust the "zero" using the wing nuts below the scale.
2. Alternatively you can just remember the value on the scale and then add or subtract required cutting depth as necessary.

4.3. Engine Turning-Off

1. Shift the throttle control lever to idle position.
2. Let the engine run idle for a while to cool down.
3. Push emergency stop button
4. Turn the on/off switch to "OFF" position.
5. Close the fuel tap

4.4. Handling, Transport, Storing

When handling the machine keep safety regulation shown in this manual and well as

general safety rules valid for operation of lifting or hoisting equipment.

4.4.1. Manual Handling

For manual lifting, cooperation of more than one person is required. Hold the machine by frame or the base plate. Never lift the machine by the engine.

4.4.2. Handling by Crane

Use a crane of sufficient payload (see Technical Data). Observe the regulations valid for operation of cranes. Only qualified personnel may carry out this work.

Fasten the lifting cable to the marked hooking point at the machine.

Fig. Hooking point



4.4.3. Handling by Forklift

Should the machine be extensively handled by a forklift (as when sending it by a transport service), it is recommended to palletize it. For

one machine use "small" palette (0,8x0,6m), for two machines standard EUR pallet (1,2x0,8m).

4.4.4. Transport

Secure the machine against rolling over, falling down or sliding on the carrier. Fasten straps to suitable points at the frame.

The machine must always be kept in upright position to prevent oil / fuel leakage.

NOTE:

4.4.5. Storing

Store the machine in a safe place, secured from theft and misuse. We recommend an indoor dry place, without excessive concentration of chemical agents and dust.

Prior to long-term storing clean the machine, repair the paint and apply suitable preservation agents. Mark visibly that the machine has been conserved.

4.5. Special Conditions of Operation

4.5.1. Work at Low Temperatures

The RVZ-500 cutter is able to work even at low temperatures. Let the engine to warm up sufficiently before commencing the work.

In case that the machine is difficult to start, let it warm up at room temperature first.

4.5.2. Work at High Altitudes

With rising altitude the engine power decreases due to changed air/fuel ratio. The engine power can be partially improved by changing of the main nozzle and different adjustment of the carburetor (gasoline engines).

In case that the engine should work long-term above 1500 m above seal level, we recommend to contact an authorized Honda service agent.

4.5.3. Work in Dusty Environment

In case of dusty environment shorten the cleaning/replacement intervals of the air filter to half.

Clean the machine from dust regularly.

5. Maintenance

The basic activities of maintenance which are described in this Manual can be carried out by the designated operator.

Repairs and adjustments beyond the extent of this Manual should be committed to an authorized service agent.

NOTE:

During the warranty period, no interventions to the engine are allowed, except for prescribed maintenance.

5.1. Maintenance of the Engine

- see enclosed Engine Operation Manual

5.2. Tensioning of the Drive Belts

check regularly tensioning of the drive belts that drive the cutting disc. Deflection of the belts under finger pressure should be about 2 cm.

To tension the belts, proceed as follows:

- loosen 4 bolts which fasten the engine to the base plate

- turn the tensioning screw to tension the belts
- re-tighten the fastening bolts

When replacing the belts, use all belts of the same type and dimension.

NOTE! Do not over-tension the belts!

5.3. Inspection of Bolted Connections

It is recommended to inspect the bolted connections daily before work.

5.4. Adjustment of Engine Speed

If in case of engine replacement or repair, it is necessary to adjust engine speed. Proceed as follows:

Engine speed can be measured either by contact or non-contact revolution meter. If the contact one is used, remove the belt cover first.

The engine speed should be 3600 RPM.

The disc spindle speed should be: 2800 RPM

NEVER ADJUST HIGHER ENGINE SPEED THAN SPECIFIED!

(The engine could be damaged due to excessive vibrations.)

The manufacturer shall not honor any warranty claims arising from excessive speed of the engine!

SPEED ADJUSTMENT SHOULD BE DONE BY AN AUTHORIZED SERVICE AGENT DURING THE WARRANTY PERIOD!

Fig. Basic groups of the cutter (see exploded views for details)

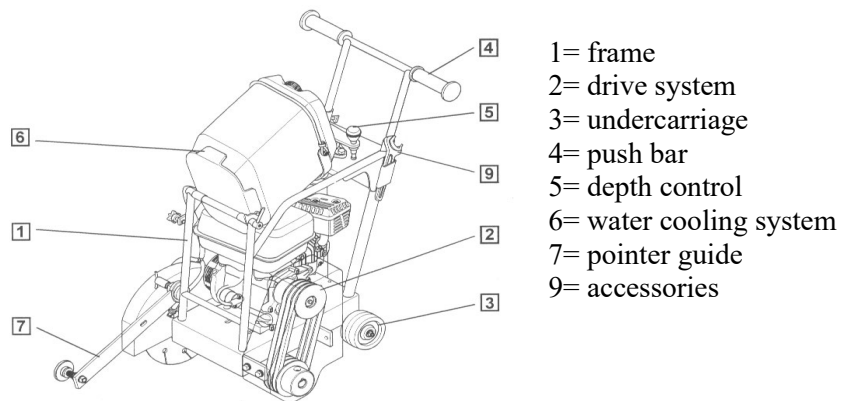

5. MAINTENANCE SCHEDULE

This maintenance schedule contains only the most important operations. Besides of these operations, carry out maintenance and repairs of the machine as necessary depending on the respective conditions of operation. Check also the engine operation manual.

WARNING:

Turn off the engine before any maintenance or repair activity.

Use genuine spare parts only. Use of non-original spare parts may lead to damage to the machine. The manufacturer will not honor any warranty claim arising from such reason.

Item	Operation	Initial inspection	After 1st month or 20 hrs.	Every 3 months or 50 hrs.	Every 6 months or 100 hrs.
Engine oil	Inspection of oil level	<input checked="" type="checkbox"/>	DAILY (3)		
	Exchange		<input checked="" type="checkbox"/>		<input checked="" type="checkbox"/>
Air filter	Inspection	<input checked="" type="checkbox"/>	DAILY (1)		
	Cleaning		If necessary (1)		
Spark plug (gasoline engines)	Inspection - cleaning				<input checked="" type="checkbox"/>
Filter bowl	Cleaning				<input checked="" type="checkbox"/>
Fuel hose	Inspection - Exchange	Every two years			
Valve clearance	Inspection - adjustment	Every 12 months or 300 hrs. (2)			
Fuel tank and sieve	Cleaning	Every 12 months or 300 hrs. (2)			
Drive belt	Tensioning			<input checked="" type="checkbox"/>	
Handle assembly	Lubrication				<input checked="" type="checkbox"/>

1. **To be carried more often when operating in dusty environment!**
2. **It is recommended to be carried out by authorized service agent.**
3. **Use the dipstick for oil level inspection (supplied with every machine as an accessory)**

1. FRAME

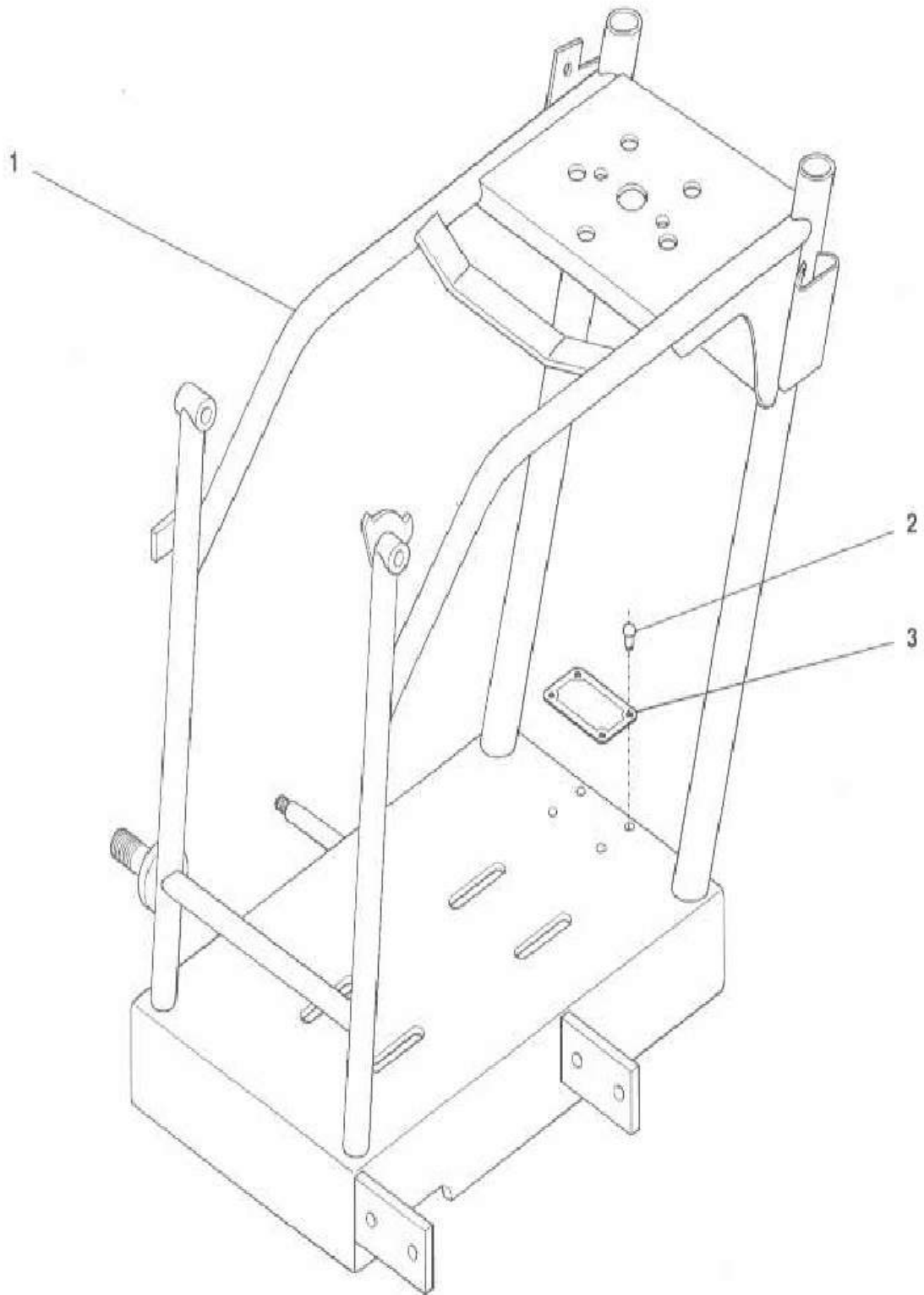

1. FRAME				
Position	Art. Nr.	Description	Qty.	Dimension
0	0000030057	Frame	1	
1	0010030057	Frame	1	
2	2219500306	Rivet	4	3x8
3	3010010001	Serial plate	1	0,5-50x70

2. DRIVE SYSTEM

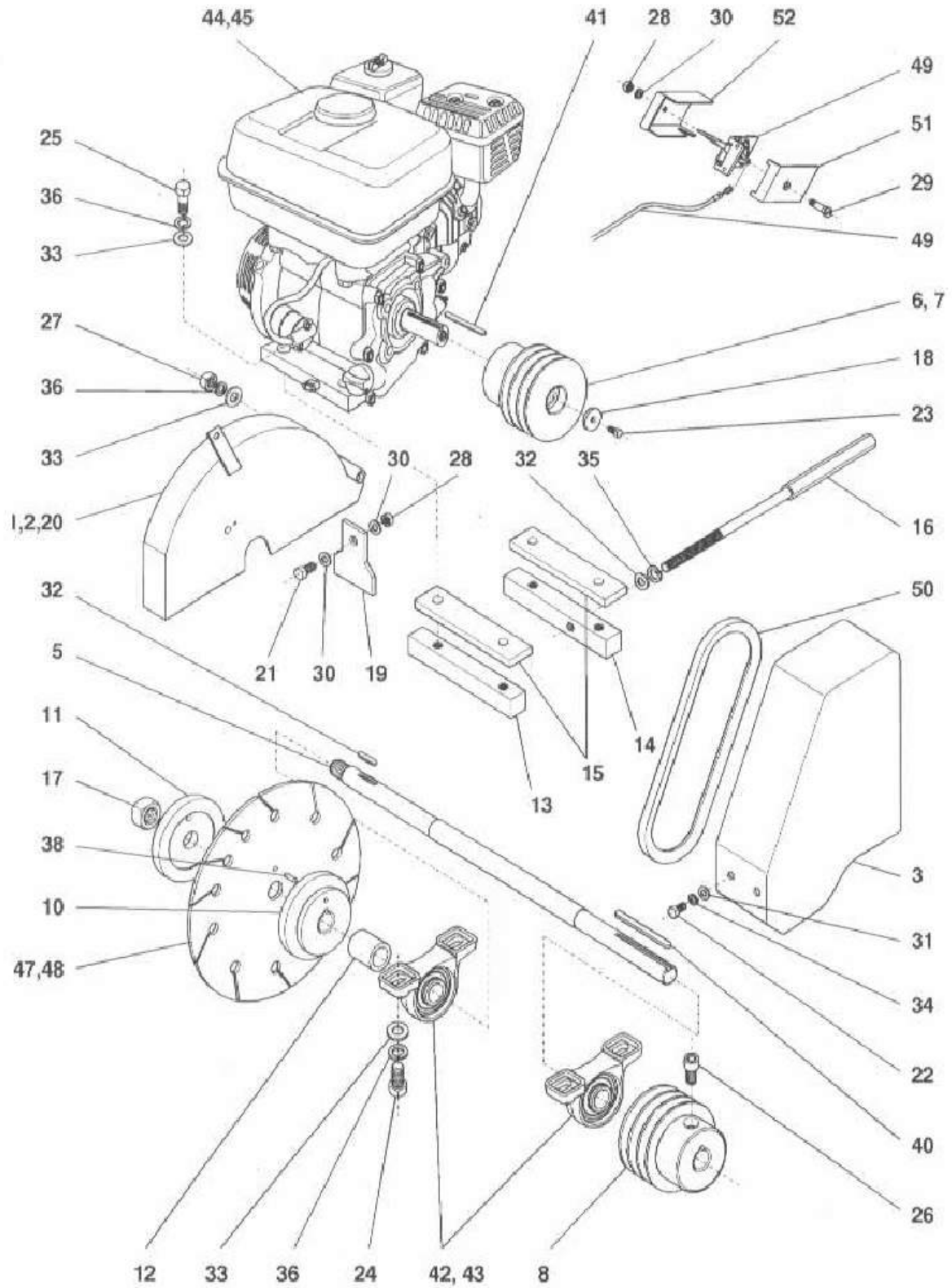

2. DRIVE SYSTEM				
Position	Art. Nr.	Description	Qty.	Dimension
0	0000030062	Drive	1	
1		N.A.	1	
2	0020030067	Protective cover	1	
3	0020030071	Belt pulley guard	1	
5	0020040160	Shaft	1	
6		N.A.	1	
7	0020040162	Belt pulley I.	1	
8	0020040163	Belt pulley II.	1	12
10	0020040164	Flange I.	1	
11	0020040165	Flange II.	1	
12	0020040166	Bush	1	
13	0020040167	Cube I.	1	
14	0020040168	Cube II.	1	
15	0020040169	Engine shim	2	
16	0020040170	Tightening screw	1	
17	0020040171	Nut	1	
18	0020040172	Washer	1	
19	0020040173	Orifice plate	1	
20	0020040214	Cover holder	1	
21	2110306012	Bolt	1	M6x12
22	2110308010	Bolt	4	M8x10
23	2110308025	Bolt	1	M8x25
24	2110112030	Bolt	4	M12x30
25	2130112060	Bolt	4	M12x60
26	2115106025	Bolt	1	M6x25
27	2140100012	Nut	1	M12
28	2140100006	Nut	2	M6
29	2115106030	Bolt	1	M6x30
30	2170200006	Washer	3	6,4
31	2170200008	Washer	4	8,4
32	2174000010	Washer	1	10,5
33	2170200013	Washer	9	13
34	2174000008	Washer	4	8
35	2174000013	Washer	1	10
36	2174000012	Washer	9	12
38	3120010014	Pin	1	10x25
38	2256287725	Feather	1	8x7x25
40	2256287780	Feather	1	8x7x80
41	2256287750	Feather	1	8x7x50
42	3110000206	Bearing	2	UCP 205
43	3742100801	Grease nipple	1	M8x1
44	3120010032	N.A.	1	
45	3120010033	Honda Engine	1	GX 390
47/48		Sawblade	1	
49	3120010010	Controller	1	22179
50	4080000800	V belt	3	
51	0050040040	Cover I.	1	
52	0050040041	Cover II.	1	

3.UNDERCARRIAGE

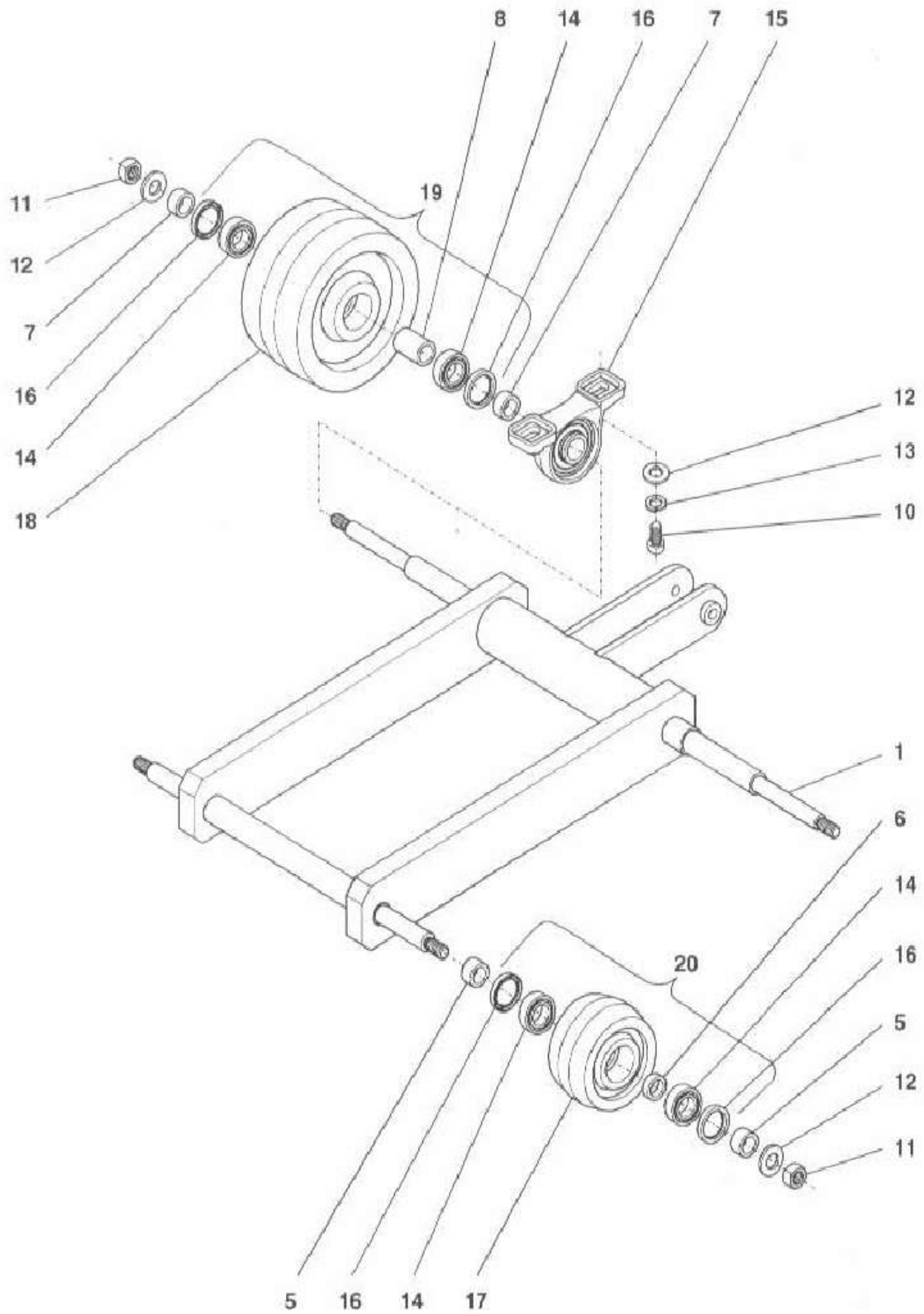

3. UNDERCARRIAGE				
Position	Art. Nr.	Description	Qty.	Dimension
1	0030030074	Undercarriage	1	
5	0030060048	Distance bush	4	TR KR 25x2,6-10
6	0030060049	Distance bush	2	TR KR 25x2,6-6
7	0030060050	Distance bush	4	TR KR 25x2,6-8
8	0030060051	Distance bush	2	TR KR 25x2,6-26
10	2130112035	Bolt	4	M12x35
11	2140100012	Nut	4	M12
12	2170200013	Washer	8	13
13	2174000012	Washer	4	12
14	3110006003	Bearing	8	6003 2RS
15	3110000204	Bearing	2	UCP 204
16	4101703507	Oil seal	8	G 25-35-7 NBR
17	3180180203	Wheel	2	5 PR 100 š. 40
18	3180180204	Wheel	2	5 PR 170 š. 60
19	0000060058	Wheel complete	2	PR 170
20	0000060059	Wheel complete	2	PR 100

4. PUSH BAR

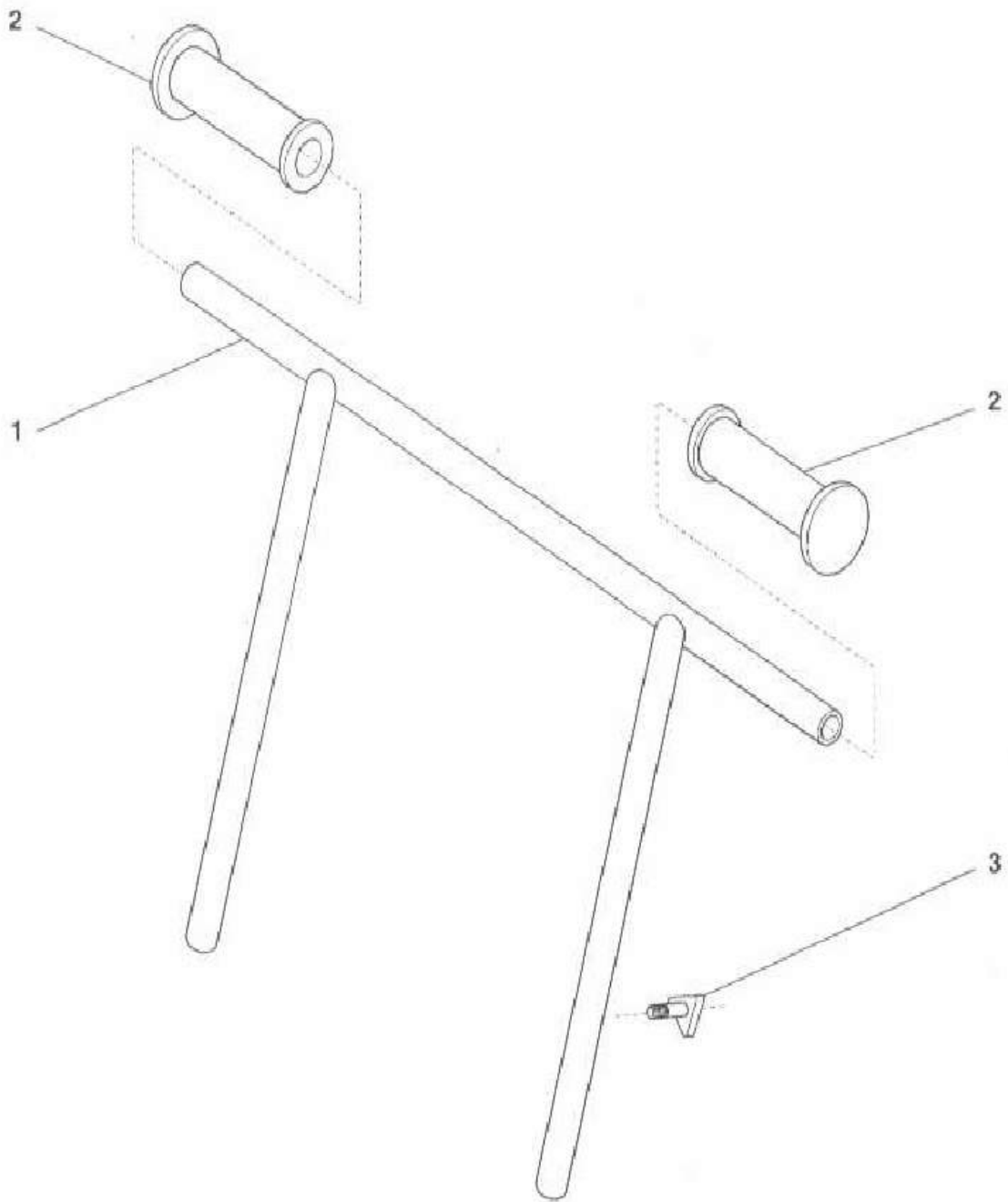

4. PUSH BAR				
Position	Art. Nr.	Description	Qty.	Dimension
1	0040030076	Handlebars	1	
2	4014014013	Grip	2	PR 22-120
3	4260000208	Bolt	2	M8 326210025

5. DEPTH CONTROL

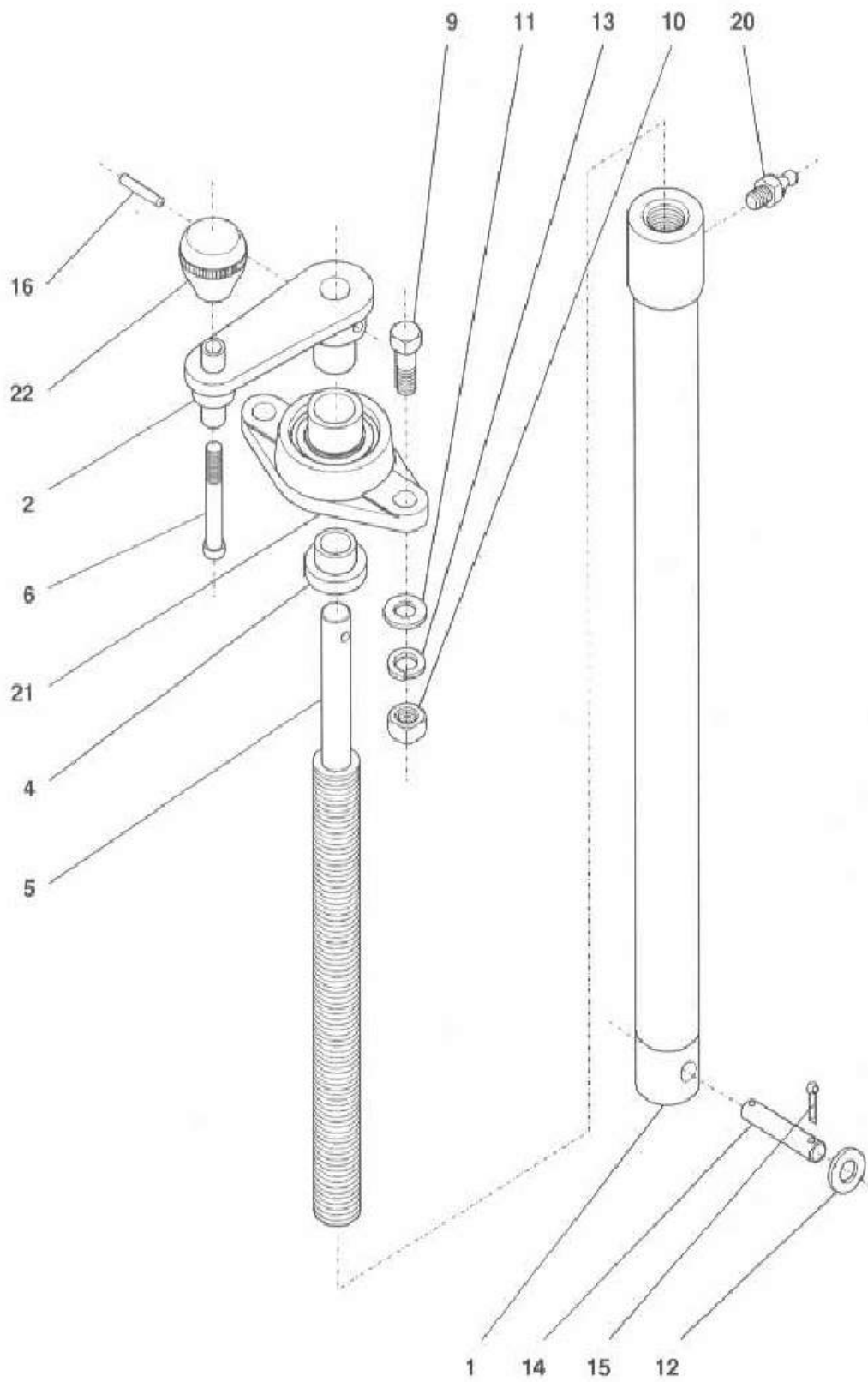

5. DEPTH CONTROL				
Position	Art. Nr.	Description	Qty.	Dimension
2	0050040188	Lever	1	
5	0050040192	Bolt	1	
6	0050040193	Rod	1	
9	2110112040	Bolt	2	M12x40
10	2140100012	Nut	2	M12
11	2170200013	Washer	4	13
12	2170200010	Washer	2	10,5
13	2174000012	Washer	2	12
14	3120010012	Pin	1	10x70
15	2178132025	Split pin	2	3,2x25
16	3120010017	Pin	1	6x32
20	3742100801	Grease nipple	1	M8x1
21	3110000207	Bearing	1	UCFL204R NSK
22	4260000110	Handle	1	M8 22E4008F

6. WATER COOLING SYSTEM

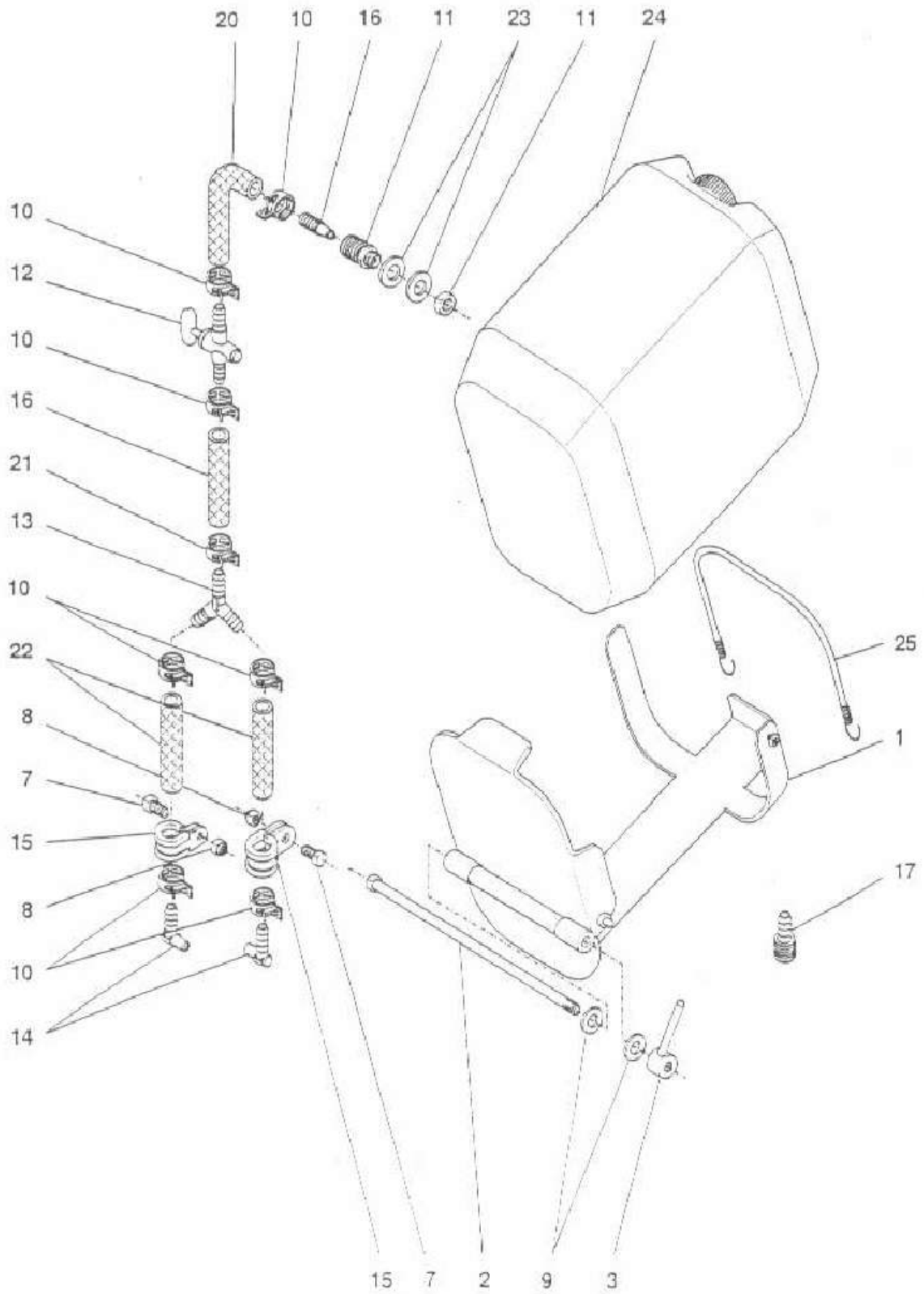

6. WATER COOLING SYSTEM				
Position	Art. Nr.	Description	Qty.	Dimension
1	0060030079	Tank support	1	
2	0060040199	Bolt	1	
3	0060040201	Nut	1	
5	0060040213	Nozzle	2	
7	2110306012	Bolt	1	M6x12
8	2140100006	Nut	1	M6
9	2170200006	Washer	2	6,4
10	3651001812	Sleeve	8	PR 16
11	3815232003	Fast coupling	1	1/2"
12	4014435001	Cock	1	1/2"
13	4014014011	Breeches piece	1	YS 14
14	4014014010	Connecting pipe	2	WS 14/10
15	3651002015	Sleeve	1	1/2"
16	3815232503	Connecting piece	1	1/2"
17	3815232004	Fast coupling	1	1/2"
20	4016017125	Hose	1	1/2" – 270
21	4016017125	Hose	1	1/2" – 170
22	4016017125	Hose	2	1/2" – 300
23	0060040091	Gasket	2	1/2"
24	4038004112	Watertank	1	20 l
25	0060060054	Fastening belt	1	500 mm

7. POINTER GUIDE

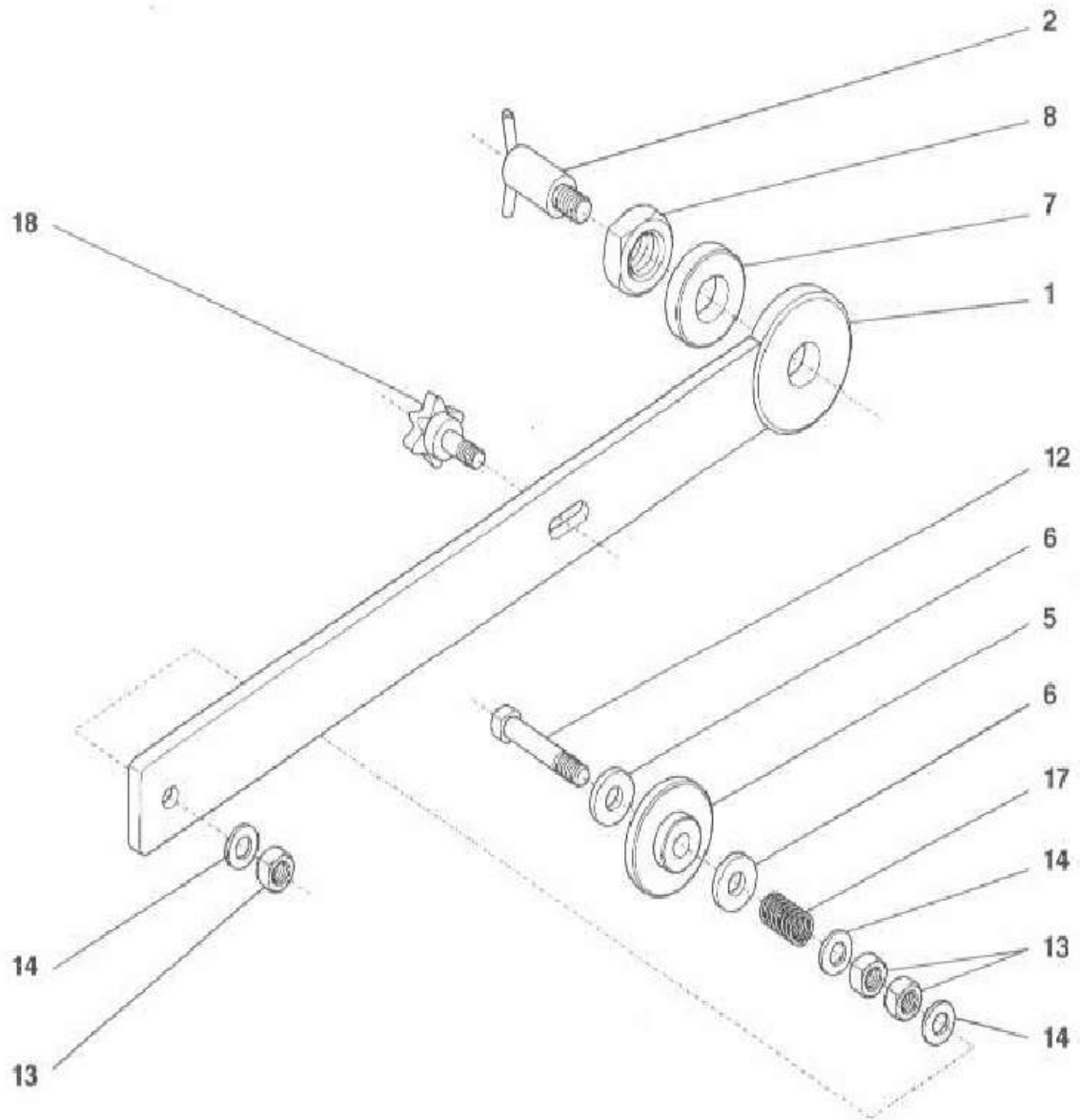

7. POINTER GUIDE				
Position	Art. Nr.	Description	Qty.	Dimension
1	0070040203	Arm	1	
2	0070040206	Bolt	1	
5	0070040209	Roller	1	
6	0070040210	Washer I.	2	
7	0070040211	Washer II.	1	
8	0070040212	Nut	1	
12	2110310080	Bolt	1	M10x80
13	2140100010	Nut	3	M10
14	2174000010	Washer	3	10,5
17	0070060056	Spring	1	PR 162-25
18	2110308020	Bolt	1	M8x20

9. ACCESSORIES

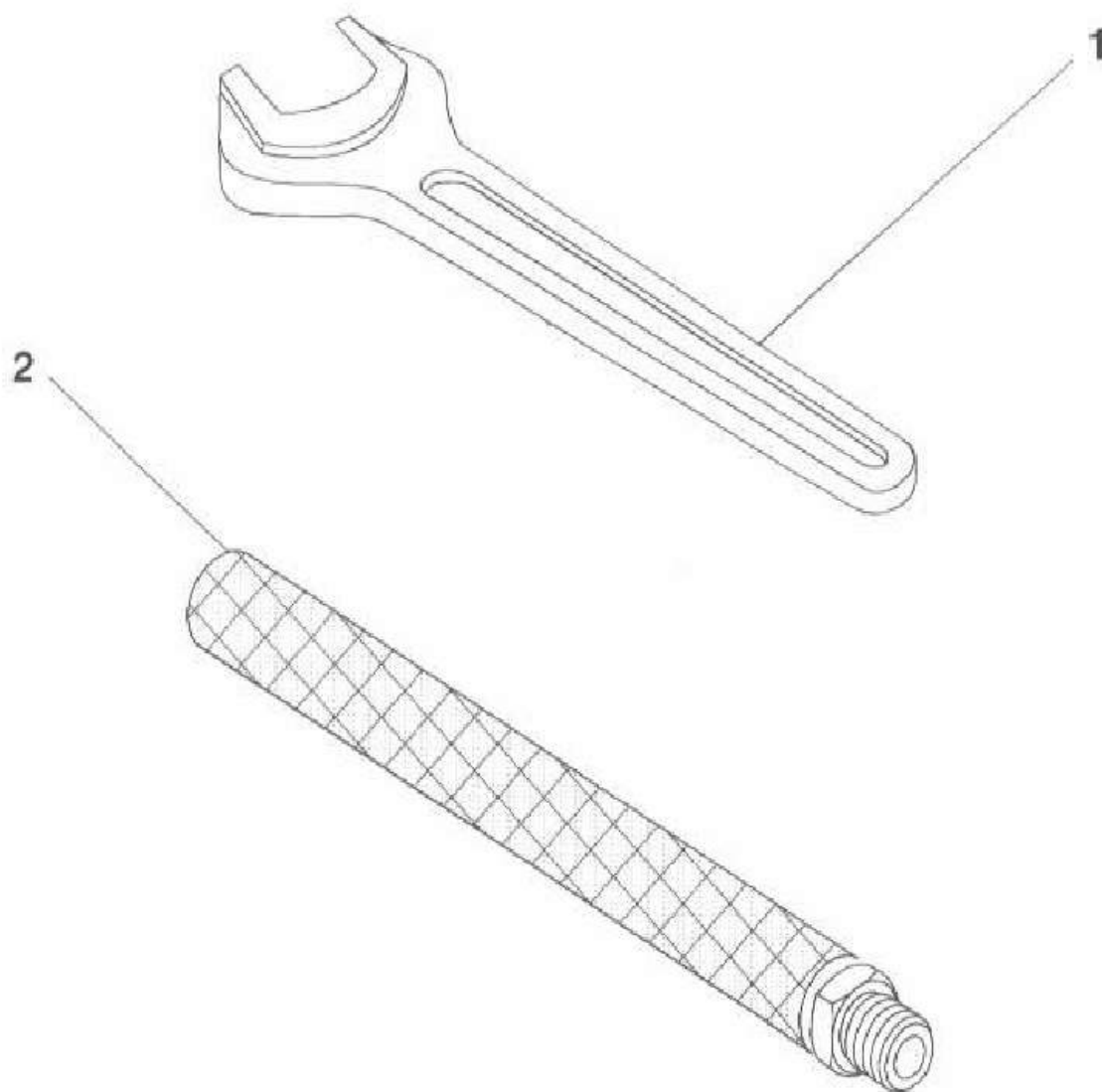

9. ACCESSORIES				
Position	Art. Nr.	Description	Qty.	Dimension
1	7640000036	Spanner	1	OK 36
2	0090060057	Hose	1	I – 350